

Strainer

BOA-S

PN 6/16/25
DN 15-400

Type Series Booklet



Legal information/Copyright

Type Series Booklet BOA-S

All rights reserved. The contents provided herein must neither be distributed, copied, reproduced, edited or processed for any other purpose, nor otherwise transmitted, published or made available to a third party without the manufacturer's express written consent.

Subject to technical modification without prior notice.

© 21/03/2017

Contents

Check Valves and Strainers	4
Strainers to DIN/EN.....	4
BOA-S.....	4
Main applications.....	4
Fluids handled	4
Operating data.....	4
Body materials.....	4
Design details	4
Product benefits.....	4
Related documents	5
Purchase order specifications	6
Pressure/temperature ratings.....	6
Materials.....	6
Dimensions and weights.....	7
Dimensions and weights of EN-GJL-250 (5.1301) variant	7
Dimensions and weights of EN-GJS-400-18-LT (5.3103) variant	9
Installation instructions	10
Chemical resistance chart	11

Check Valves and Strainers

Strainers to DIN/EN

BOA-S



Main applications

- Hot-water heating systems
- Air-conditioning systems
- Process engineering
- Chemical industry
- Petrochemical industry
- Sugar industry
- Heat recovery systems
- Boiler feed applications
- Boiler recirculation
- Pulp and paper industry

Fluids handled

- Hot water
- Saturated steam
- Thermal oil
- Liquids and gases not chemically or mechanically aggressive to the valve materials.
- Other fluids on request.

Operating data

Operating properties

Characteristic	Value	
	EN-GJL-250	EN-GJS-400-18-LT
Nominal pressure	PN 6/16	PN 16/25
Nominal size	DN 15 - 400	DN 15 - 300
Max. permissible pressure [bar]	16	25
Min. permissible temperature [°C]	-10	-10
Max. permissible temperature [°C]	+300	+350

Selection as per pressure/temperature ratings (⇒ Page 6)

Body materials

Overview of available materials

Material	Material number	Temperature limit
EN-GJL-250	5.1301	≤ 300 °C
EN-GJS-400-18-LT	5.3103	≤ 350 °C

Design details

Design

- Y-pattern strainer
- Screen made of stainless steel
- Screen accurately guided in cover and body
- Outside confined cover gasket
- Drain plug
- Size DN 150 and above: additional screen cage made of perforated stainless steel sheet
- Flanges to DIN EN 1092-2 Type 21
- Exterior coating: blue, RAL 5002
- The valves satisfy the safety requirements of Annex I of the European Pressure Equipment Directive 2014/68/EU (PED) for fluids in Groups 1 and 2.
- The valves do not have a potential internal source of ignition and can be used in potentially explosive atmospheres, Group II, category 2 (zones 1+21) and category 3 (zones 2+22) to ATEX 2014/34/EU.

Variants

- Fine mesh
- High temperature resistant paint, aluminium grey (EN-GJS-400-18-LT only)
- Other flange designs (EN-GJS-400-18-LT only)
- Certification to customer specification

Product benefits

- Long service life due to stainless steel screen.
- Time and cost saving replacement of screen without removing the body insulation by using the studs as centering aids.
- Standard drain plug for easy inspection and drainage of strainer, particularly of large-diameter strainers.

Related documents

Information/documents

Document	Reference number
Operating manual	0570.8

Purchase order specifications

Please specify the following information in all enquiries or purchase orders:

1. Type
2. Nominal pressure
3. Nominal size

4. Material
5. Variants
6. Reference number

Pressure/temperature ratings

Test pressure and operating pressure

PN	Material	Shell and leak test	Permissible operating pressure [bar] ¹⁾²⁾							
		With water	[°C]							
		Tests P10 and P11 to DIN EN 12266-1	-10 to +120	150	180	200	230	250	300	350
6	EN-GJL-250	9	6	5,4	5	4,8	4,4	4,2	3,6	-
16		24	16	14,4	13,4	12,8	11,8	11,2	9,6	-
16	EN-GJS-400-18-LT	24	16	15,5	-	14,7	-	13,9	12,8	11,2
25		37,5	25	24,3	-	23	-	21,8	20	17,5

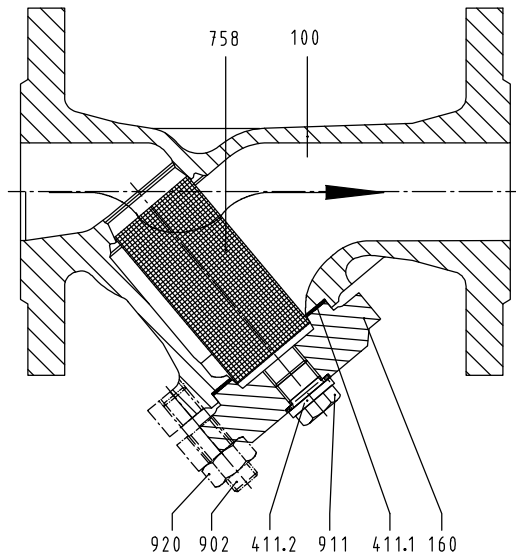
Materials

Fig. 1: BOA-S
Parts list

Part No.	Description	PN	Material	Note
100	Body	6, 16	EN-GJL-250 (5.1301)	-
		16, 25	EN-GJS-400-18-LT (5.3103)	-
160 ³⁾	Cover	6,16	EN-GJL-250 (5.1301)	-
		16, 25	EN-GJS-400-18-LT (5.3103)	-
411.1 ⁴⁾	Joint ring	6, 16	CrNi steel/graphite	-
		16, 25	CrNi steel/graphite	-
411.2	Joint ring	6, 16, 25	A4	-
758 ⁴⁾	Screen	6, 16	X 6 CrNiTi 18 10 (1.4541)	-
		16, 25	X 5 CrNi 18 10 (1.4301)	-
191	Screen cage	6, 16	X 6 CrNiTi 18 10 (1.4541)	≥ DN 150
		16, 25	X 5 CrNi 18 10 (1.4301)	≥ DN 150
902	Stud	6, 16	5.6 or 8.8	gal ZN
		16, 25	C 35 E	gal ZN

- 1) Intermediate temperatures can be derived by linear interpolation.
- 2) Static load
- 3) Spare part (complete with screw plug)
- 4) Spare part

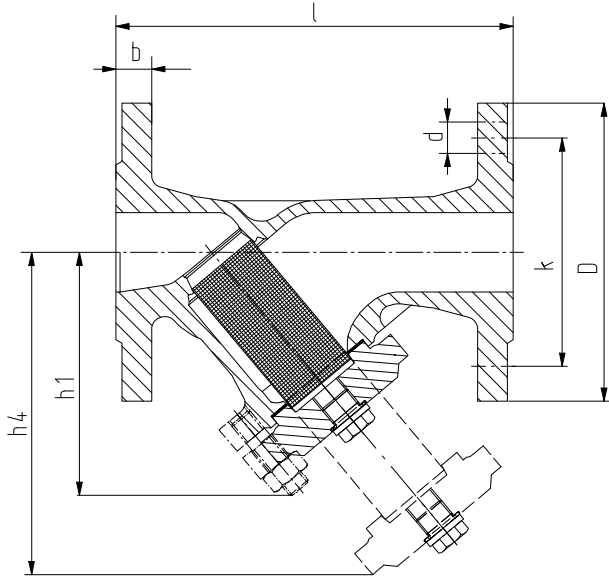
Part No.	Description	PN	Material	Note
911	Drain plug	6, 16	A4 or A2	-
		16, 25	C 35 E	gal ZN
920	Hexagon nut	6, 16	5-2 or 8	gal ZN
		16, 25	C 35 E	gal ZN

Dimensions and weights
Dimensions and weights of EN-GJL-250 (5.1301) variant

Fig. 2: BOA-S
Dimensions [mm] and weights [kg]

PN	DN	l	D	k	n × d	b	h ₁	h ₄	Drain plug	[kg]
6	15	130	80	55	4 × 11	12	90	135	G 3/8"	2,5
	20	150	90	65	4 × 11	14	100	160	G 3/8"	3
	25	160	100	75	4 × 11	14	115	180	G 3/8"	4,5
	32	180	120	90	4 × 14	16	135	215	G 3/8"	5,5
	40	200	130	100	4 × 14	16	150	240	G 3/8"	7
	50	230	140	110	4 × 14	16	160	250	G 3/8"	9
	65	290	160	130	4 × 14	16	180	285	G 1/2"	13
	80	310	190	150	4 × 18	18	215	330	G 1/2"	19
	100	350	210	170	4 × 18	18	240	395	G 1/2"	26
	125	400	240	200	8 × 18	20	280	455	G 1/2"	38
	150	480	265	225	8 × 18	20	330	525	G 1/2"	54
200	600	320	280	8 × 18	22	405	650	G 1/2"	110	
16	15	130	95	65	4 × 14	14	90	135	G 3/8"	3
	20	150	105	75	4 × 14	16	100	160	G 3/8"	4
	25	160	115	85	4 × 14	16	115	180	G 3/8"	5
	32	180	140	100	4 × 18	18	135	215	G 3/8"	7
	40	200	150	110	4 × 18	18	150	240	G 3/8"	9
	50	230	165	125	4 × 18	20	160	250	G 3/8"	12
	65	290	185	145	4 × 18	20	180	285	G 1/2"	16
	80	310	200	160	8 × 18	22	215	330	G 1/2"	21
	100	350	220	180	8 × 18	24	240	395	G 1/2"	30
	125	400	250	210	8 × 18	26	280	455	G 1/2"	43
	150	480	285	240	8 × 22	26	330	525	G 1/2"	61
	200	600	340	295	12 × 22	30	405	650	G 1/2"	121
	250	730	405	355	12 × 26	32	540	870	G 1/2"	154
	300	850	460	410	12 × 26	32	680	1110	G 1/2"	255
350	980	520	470	16 × 28	36	755	1200	G 1 1/2"	373	
400	1100	580	525	16 × 31	38	835	1320	G 1 1/2"	540	

Dimensions [mm]

PN	DN	Standard mesh				Fine mesh			
		Kv [m³/h]	Zeta value	Mesh width	Wire diameter	Kv [m³/h]	Zeta value	Mesh width	Wire diameter
6	15	5,7	2,5	1,0	0,5	5,3	2,9	0,25	0,16
	20	10,4	2,4	1,0	0,5	9,5	2,8	0,25	0,16
	25	16,4	2,3	1,0	0,5	15,1	2,7	0,25	0,16
	32	27,3	2,3	1,0	0,5	24,7	2,7	0,25	0,16
	40	42	2,3	1,0	0,5	38,2	2,8	0,25	0,16
	50	64,7	2,4	1,0	0,5	57,2	3,0	0,25	0,16
	65	96	3,1	1,25	0,63	81,1	4,3	0,25	0,16
	80	149	3,0	1,25	0,63	119	4,6	0,25	0,16
	100	223	3,2	1,6	1,0	181	4,9	0,25	0,16
	125	347	3,2	1,6	1,0	281	5,0	0,25	0,16
	150	480	3,5	1,6	1,0	380	5,6	0,25	0,16
200	853	3,5	1,6	1,0	672	5,7	0,25	0,16	
16	15	5,7	2,5	1,0	0,5	5,3	2,9	0,25	0,16
	20	10,4	2,4	1,0	0,5	9,5	2,8	0,25	0,16
	25	16,4	2,3	1,0	0,5	15,1	2,7	0,25	0,16
	32	27,3	2,3	1,0	0,5	24,7	2,7	0,25	0,16
	40	42	2,3	1,0	0,5	38,2	2,8	0,25	0,16
	50	64,7	2,4	1,0	0,5	57,2	3,0	0,25	0,16
	65	96	3,1	1,25	0,63	81,1	4,3	0,25	0,16
	80	149	3,0	1,25	0,63	119	4,6	0,25	0,16
	100	223	3,2	1,6	1,0	181	4,9	0,25	0,16
	125	347	3,2	1,6	1,0	281	5,0	0,25	0,16
	150	480	3,5	1,6	1,0	380	5,6	0,25	0,16
	200	853	3,5	1,6	1,0	672	5,7	0,25	0,16
	250	1104	5,1	1,6	1,0	838	8,9	0,25	0,16
	300	1450	6,1	1,6	1,0	1090	10,9	0,25	0,16
	350	1800	7,4	1,6	1,0	1339	13,1	0,25	0,16
	400	2200	8,4	1,6	1,0	1640	14,9	0,25	0,16

Mating dimensions as per standard

Face-to-face lengths: DIN EN 558/1, ISO 5752/1

Flanges: DIN EN 1092-2, flange type 21

Flange facing: DIN EN 1092-2, type B

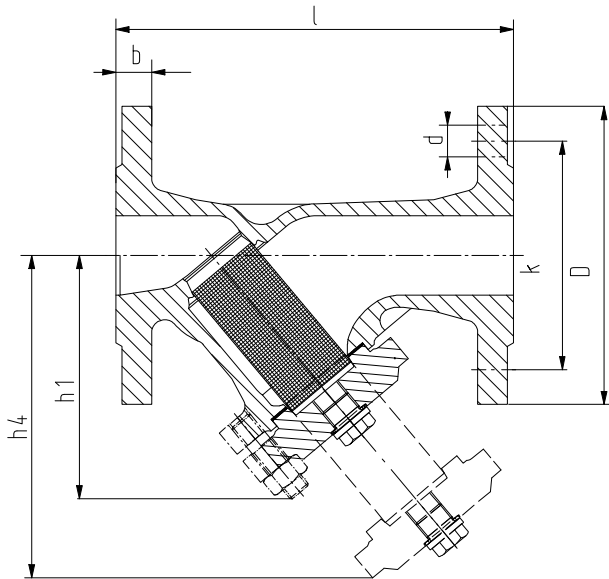
Dimensions and weights of EN-GJS-400-18-LT (5.3103) variant

Fig. 3: BOA-S

Dimensions [mm] and weights [kg]

PN	DN	l	D	k	n × d	b	h ₁	h ₄	Drain plug	[kg]
16	15	130	95	65	4 × 14	16	75	115	G ½"	3,5
	20	150	105	75	4 × 14	18	75	115	G ½"	4
	25	160	115	85	4 × 14	18	90	135	G ½"	5,5
	32	180	140	100	4 × 18	20	90	135	G ½"	7
	40	200	150	110	4 × 18	20	110	170	G ½"	9
	50	230	165	125	4 × 18	22	120	190	G ½"	12
	65	290	185	145	4 × 18	24	140	220	G ½"	16
	80	310	200	160	8 × 18	26	165	265	G 1"	21
	100	350	220	180	8 × 18	28	220	340	G 1"	28
	125	400	250	210	8 × 18	30	260	410	G 1"	41
25	15	130	95	65	4 × 14	16	75	115	G ½"	3,5
	20	150	105	75	4 × 14	18	75	115	G ½"	4
	25	160	115	85	4 × 14	18	90	135	G ½"	5,5
	32	180	140	100	4 × 18	20	90	135	G ½"	7
	40	200	150	110	4 × 18	20	110	170	G ½"	9
	50	230	165	125	4 × 18	22	120	190	G ½"	12
	65	290	185	145	8 × 18	24	140	220	G ½"	16
	80	310	200	160	8 × 18	26	165	265	G 1"	21
	100	350	235	190	8 × 22	28	220	340	G 1"	32
	125	400	270	220	8 × 26	30	260	410	G 1"	47
150	480	300	250	8 × 26	34	300	475	G 1"	64	
200	600	360	310	12 × 26	34	360	580	G 1"	133	

Dimensions [mm]

PN	DN	Standard mesh				Fine mesh			
		Kv [m³/h]	Zeta value	Mesh width	Wire diameter	Kv [m³/h]	Zeta value	Mesh width	Wire diameter
16	15	6,3	2,1	1,25	0,71	5,0	3,2	0,25	0,17
	20	11,3	2,0	1,25	0,71	9,0	3,2	0,25	0,17
	25	18,5	1,8	1,25	0,71	14,8	2,9	0,25	0,17
	32	22,5	3,3	1,25	0,71	18,0	5,2	0,25	0,17
	40	37,5	2,9	1,25	0,71	30,0	4,6	0,25	0,17
	50	60,0	2,8	1,25	0,71	48,0	4,4	0,25	0,17
	65	110,5	2,3	2,0	0,50	85,0	4,0	0,25	0,17
	80	170,3	2,3	2,0	0,50	131,0	3,8	0,25	0,17

PN	DN	Standard mesh				Fine mesh			
		Kv [m³/h]	Zeta value	Mesh width	Wire diameter	Kv [m³/h]	Zeta value	Mesh width	Wire diameter
16	100	245,7	2,7	2,0	0,50	189,0	4,5	0,25	0,17
	125	416,0	2,3	2,0	0,50	320,0	3,8	0,25	0,17
	150	608,4	2,2	2,0	0,50	494,0	3,3	0,25	0,17
	200	999,7	2,6	2,0	0,50	818,0	3,8	0,25	0,17
	250	1440,4	3,0	2,0	0,50	1184,0	4,5	0,25	0,17
	300	1976,0	3,3	2,0	0,50	1631,0	4,9	0,25	0,17
25	15	6,3	2,1	1,25	0,71	5,0	3,2	0,25	0,17
	20	11,3	2,0	1,25	0,71	9,0	3,2	0,25	0,17
	25	18,5	1,8	1,25	0,71	14,8	2,9	0,25	0,17
	32	22,5	3,3	1,25	0,71	18,0	5,2	0,25	0,17
	40	37,5	2,9	1,25	0,71	30,0	4,6	0,25	0,17
	50	60,0	2,8	1,25	0,71	48,0	4,4	0,25	0,17
	65	110,5	2,3	2,0	0,50	85,0	4,0	0,25	0,17
	80	170,3	2,3	2,0	0,50	131,0	3,8	0,25	0,17
	100	245,7	2,7	2,0	0,50	189,0	4,5	0,25	0,17
	125	416,0	2,3	2,0	0,50	320,0	3,8	0,25	0,17
	150	608,4	2,2	2,0	0,50	494,0	3,3	0,25	0,17
	200	999,7	2,6	2,0	0,50	818,0	3,8	0,25	0,17

Mating dimensions as per standard

Face-to-face lengths: DIN EN 558/1, ISO 5752/1
 Flanges: DIN EN 1092-2, flange type 21-2
 Flange facing: DIN EN 1092-2, type B

Installation instructions

- The flow direction must correspond to the arrow indicated on the valve body.
- In both horizontal and vertical pipes, installing the strainer with the screen hanging downwards is recommended to facilitate cleaning.

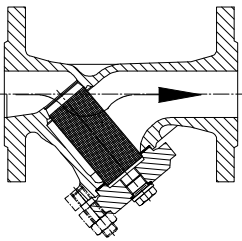

Horizontal installation

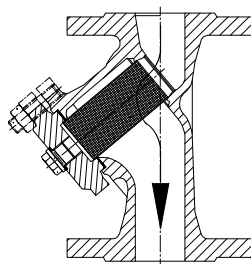

Vertical installation

Chemical resistance chart

The information provided in this chemical resistance chart is based on experience, the Dechema lists as well as manufacturer information. Corrosion resistance is largely dependent on the operating conditions, temperatures and concentrations. Hydroabrasive wear in fluids containing solids is not covered in this list. All information provided herein, therefore, only serves as an orientation. Warranty claims may not be asserted on the basis of this list!

Symbols key

Symbol	Description
✓	The fluid handled is not normally aggressive toward the materials.
✘	The fluid handled is aggressive toward the materials. Valve cannot be used.
○	The material or valve can only be used under certain operating conditions. Please enquire accordingly, stating the operating conditions such as concentration, temperature, pH and composition of the fluid handled.

Chemical resistance chart for water⁵⁾

Fluids handled	A ⁶⁾	B ⁷⁾
Brackish water ⁸⁾	✘	✘
Service water ⁸⁾	✓	✓
Fire-fighting water	✓	✓
Chlorinated water (≤ 0.6 mg/kg)	✓	✓
Deionised water (demineralised water) ⁹⁾	○	○
Distilled water ⁹⁾	○	○
Boiler feed water	✓	✓
Hot water	✓	✓
High-temperature hot water	✓	✓
Condensate	✓	✓
Oil-free cooling water	✓	✓
Oil-containing cooling water	✓	✓
Ozonised water (≤ 0.5 mg/kg)	✓	✓
Pure water	✓	✓
Seawater	✘	✘
Scale-forming water ⁸⁾	○	○
Raw water ⁸⁾	✓	✓
Partly desalinated water ⁹⁾	○	○
Fully desalinated water ⁹⁾	○	○
Municipal waste water ⁸⁾¹⁰⁾	✓	✓
Industrial waste water ⁸⁾¹¹⁾	✓	✓

Chemical resistance chart for oils (aromatic content 5 mg/kg)

Fluids handled	A ⁶⁾	B ⁷⁾
Vegetable oils	✓	✓
Mineral oils	✓	✓
Synthetic oils	✓	✓
Crude oil	✓	✓
Petroleum	✓	✓
Light fuel oil	✓	✓

Fluids handled	A ⁶⁾	B ⁷⁾
Linseed oil	✓	✓
Oil/water emulsion ⁸⁾	✓	✓
Jet fuel	○ ¹²⁾	✓
Petrol	○ ¹²⁾	✓
Kerosene	○ ¹²⁾	✓

Chemical resistance chart for refrigerants

Fluids handled	A ⁶⁾	B ⁷⁾
Ammonium hydroxide (≤ 30 %, ≤ 25 °C)	✓	✓
Glycol (ethylene glycol)	✓	✓
Propylene glycol	✓	✓
Water/glycol mixture (20 % ≤ c ≤ 50 %, ≤ 90 °C)	✓	✓
Inorganic cooling brine, pH 7.5	✓	✓

Chemical resistance chart for thermal oils

Fluids handled	A ⁶⁾	B ⁷⁾
Synthetic thermal oils	✓	✓
Mineral-based thermal oils	✓	✓

Chemical resistance chart for acids

Fluids handled	A ⁶⁾	B ⁷⁾
Hydrochloric acid	✘	✘
Sulphuric acid (pure, technical, concentrated)	✘	✘
Sulphurous acid	✘	✘
Fatty acid	✘	✘
Nitric acid	✘	✘

Chemical resistance chart for cleaning agents

Fluids handled	A ⁶⁾	B ⁷⁾
Lye for bottle rinsers (e.g. P3) ≤ 80 °C ⁸⁾	○	○
Lye for metal cleaning ≤ 80 °C ⁸⁾	○	○

Chemical resistance chart for steam

Fluids handled	A ⁶⁾	B ⁷⁾
Saturated steam	○ ¹²⁾	✓

Chemical resistance chart for other fluids

Fluids handled	A ⁶⁾	B ⁷⁾
Sodium hydroxide (≤ 50 %, ≤ 50 °C)	○	○
Natural gas	✓	✓
Oil-containing compressed air	✓	✓
Dry chlorine (≤ 30 °C)	○	✓
Ammonia	✓	✓
Butane (liquefied gas)	✓	✓
Aqueous glycerine	✓	✓
Carbon dioxide (gas)	✓	✓
Carbon dioxide (aqueous solution)	✘	✘

- 5) General criteria for water to be handled by products made of non-alloyed materials: pH > 7; chlorides (Cl⁻) < 150 mg/kg; chlorine (Cl₂) < 0.6 mg/kg. Other factors to be considered: hardness, carbon dioxide content (CO₂), oxygen (O₂) and dissolved substances. Contact KSB if limits are exceeded!
- 6) EN-GJL-250, T_{max.} +300 °C
- 7) EN-GJS-400-18-LT, T_{max.} +350 °C
- 8) Without solids
- 9) Can only be used for installations and the respective water quality as specified in the VdTÜV 1466 or VDI 2035 guidelines. A pH ≥ 9.5 and an oxygen content of ≤ 0.02 mg/l are also recommended.
- 10) Biologically treated
- 11) Non-corrosive, non-abrasive
- 12) EN-GJS-400-18-LT is recommended for safety reasons (ductility).