

The Multivariable Air Flow Meter

Model MVC10A/MVC10F

OVERVIEW

The Multivariable Mass Flow Meter model MVC10A/MVC10F, a compact flow meter has all function necessary to measure nitrogen (N₂) gas, carbon dioxide (CO₂) gas and air. The model MVC10A/MVC10F can accurately measure differential pressure, static pressure, and process temperature to dynamically calculate fully compensated mass flow of factory compressed air, and N₂ gas in food and beverage for anti-oxidation.

The model MVC10A/MVC10F is very useful to save energy with indicating cost of air, N₂, CO₂ and leak-check function.

FEATURES

High accuracy

A state-of-the-art Dual Sensor realizes accurate measurement of mass flow rate by measuring Differential Pressure (DP), Gauge Pressure (GP), and Temperature (T) for the density compensation.

Full display function

Model MVC10A/MVC10F can display volume flow and mass flow, and velocity or pressure.

Stable measurement

- The streamline shaped flow tube (tube) can minimize the scaling and the clogging.
- Output is with excellent reproducibility due to smooth and stable streamline by elliptic tube. The rangeability of flow rate is as wide as 1 to 30, so measurement is possible down to almost zero flow rate.
- Even with a short upstream length, it provides high accuracy.

Unique functions

- **Cost indication**
To save energy management, it has cost indication.
- **Auto ranging function**
The measuring range can automatically set with memorizing maximum flow even if the actual flow rate is unknown.
- **Leak check function**
Measuring pressure in pipe with built-in pressure sensor, indicate leak rate necessary to economize energy.



APPLICATIONS

- Measuring air flow each manufacturing process
- Promoting economized energy to grasp actual consumption of air each factory and shop
- Observing capacity of equipment
- Measuring flow of N₂ & CO₂ gas

PRINCIPLE

The model MVC10A/MVC10F is a differential pressure flow meter based on the Bernoulli theorem.

Flow (Q) is calculated by the following equation.

$$Q = A \sqrt{(\Delta P) / \rho}$$

$$\rho = \frac{(P1 + 101.325)}{101.325} \times \frac{273.15}{(273.15 + T1)}$$

ΔP : Actual differential pressure

ρ : Density of gas

$P1$: Primary pressure

$T1$: Temperature

A : Flow coefficient

Detector specifications

Size: 50, 65, 80, 100, 150 mm

Process connection: Flange JIS 10K

Weight: 9 kg (50 mm), 11 kg (65 mm), 13 kg (80 mm),
18.5 kg (100 mm), 39.5 kg (150 mm)

Material

Wetted material: SUS316
 Detector: SCS13 (SUS304 for 150mm only)
 Detector cover: SCS13
 Base: SUS304
 Case: Aluminum alloy
 Cover: Polycarbonate
 Bolts and nuts materials: SUS304
 Tube for remote type: Nylon (maximum 20 m)*
 Tube fitting: Brass + POM

Note) *: One tube of 20 m is attached.

Manufacturer: NIHON PISCO Co. Ltd. in Japan.

Tube: NA0640-20R (the outside diameter: 6 mm, the inside diameter: 4 mm)

Converter case fitting (only Aluminum case):

Based acrylic paint

Install position: Horizontal or vertical

Mounting: Integral type or remote type

Installation: Detector/Converter integral type, Wall mounting, 2-inch pipe mounting

Straight pipe lengths: The minimum straight pipe length.

Determine the length of a straight pipe section by referring to the following table.

It is the minimum length of a straight pipe section required for the connection between this instrument and each joint of the upstream and downstream sides of the instrument.

Each number in the table denotes a multiple of the pipe diameter

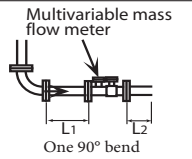
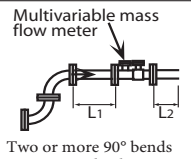
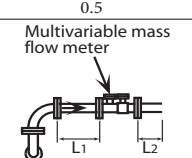
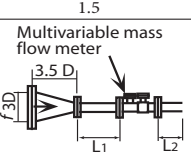
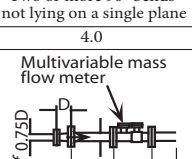
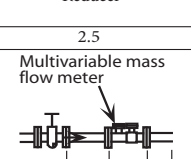
Upstream side L1		Downstream side L2
 <p>Multivariable mass flow meter</p> <p>One 90° bend</p> <p>0.5</p>	 <p>Multivariable mass flow meter</p> <p>Two or more 90° bends on a single plane</p> <p>1.5</p>	All the joints shown to the left
 <p>Multivariable mass flow meter</p> <p>Two or more 90° bends not lying on a single plane</p> <p>4.0</p>	 <p>Multivariable mass flow meter</p> <p>Reducer</p> <p>2.5</p>	
 <p>Multivariable mass flow meter</p> <p>Expansion pipe</p> <p>1.5</p>	 <p>Multivariable mass flow meter</p> <p>Sluice valve (fully open)</p> <p>2.5</p>	

Note) Valves in this figure are the gate valve, ball valve but not globe valve.

Operating environment conditions: Sheltered area only, JIS C1804 Class C2 or the equivalent

Avoid direct sunlight, even indoors. If used outdoors, use a cover, etc., to avoid the direct effects of rain and sunlight.

Ambient temperature limit: -15 to +50°C

Ambient humidity limit: 5 to 95% RH

Electrical conduit: G1/2 (3 ports)

Type of protection: IEC60529 IP54

Power supply: 90 to 250V AC

Power consumption: 5 W (maximum)

Grounding:

The most effective grounding method is direct connection to earth ground with minimal impedance. Grounding resistance lower than 100 Ω.

Output signal

Analog output: 4 to 20 mA DC

Pulse output: Open collector output

ON residual voltage: 2.6V or less

OFF leakage current: 0.10 mA or less

Pulse width:

Pulse width(m3/pulse)	Pulse weight
0.01 < Pulse weight < 0.10	1
0.10 < Pulse weight < 1.00	10

Pulse frequency: 0.005 to 500 Hz

Supply voltage: 10 to 30V DC

Max current: 50 mA

Display

Main display

Displayed value	Number of digits
Totalized flow	8-digit integer
Instantaneous flow rate	_/: 6-digit integer + 2 decimal places
	_/:min: 7-digit integer + 1 decimal place
	_/:h: 8-digit integer
	_/:day: 8-digit integer
Totalized cost	8-digit integer
Instantaneous cost	_/: 6-digit integer + 2 decimal places
	_/:min: 7-digit integer + 1 decimal place
	_/:h: 8-digit integer
	_/:day: 8-digit integer
Instantaneous % output	3-digit integer + 2 decimal places

Sub-display

Displayed value	Number of digits
Totalized flow	8-digit integer
Instantaneous flow rate	_/: 6-digit integer + 2 decimal places
	_/:min: 7-digit integer + 1 decimal place
	_/:h: 8-digit integer
	_/:day: 8-digit integer
Totalized cost	8-digit integer
Instantaneous cost	_/: 6-digit integer + 2 decimal places
	_/:min: 7-digit integer + 1 decimal place
	_/:h: 8-digit integer
	_/:day: 8-digit integer
Instantaneous % output	3-digit integer + 2 decimal places
Flow velocity (m/s)	6-digit integer + 2 decimal places
Pressure (MPa)	2-digit integer + 2 decimal places

Units of display

Displayed value	Displayed value	Number of digits
1	Totalized flow*1	m3, kg, t
2	Instantaneous flow rate*2	_/s, _/min, _/h, _/day
3	Totalized cost*3	¥, \$
4	Instantaneous cost*4	_/s, _/min, _/h, _/day

*1. If the unit of totalized flow is “t,” “_/s” cannot be selected for the unit of instantaneous flow rate.

*2. The underscore indicates the unit specified for totalized flow. If the unit of totalized flow is changed, this will change accordingly.

*3. If the unit of totalized cost is changed, the cost rate will be set to 0 (¥(\$)/m3).

*4. The underscore indicates the unit specified for totalized cost. If the unit of totalized cost is changed, this will change accordingly.

Measuring fluid: Compressed air, N₂ and CO₂

Fluid pressure

0.05 to 0.98 MPaG (Remote type: 0.05 to 0.9 MPaG)

Fluid temperature limit: -15 to +70°C

Temperature effect

±0.05%/°C of reading

Measuring flow range

Table 1. Air/N₂

Pressure [MPaG]	Size									
	50 mm		65 mm		80 mm		100 mm		150 mm	
	Maximum flow value	Minimum flow value	Maximum flow value	Minimum flow value	Maximum flow value	Minimum flow value	Maximum flow value	Minimum flow value	Maximum flow value	Minimum flow value
0.98	1400	40	2300	65	3200	90	5500	150	12000	330
0.90	1300	40	2200	65	3100	85	5000	150	11500	310
0.80	1200	35	2100	60	2900	80	5000	140	10500	300
0.70	1200	35	2000	60	2700	75	4500	130	10000	280
0.60	1100	30	1800	55	2500	70	4000	120	9000	260
0.50	1000	30	1700	50	2300	65	4000	110	8500	240
0.40	900	25	1500	45	2000	60	3500	100	7500	220
0.30	750	25	1300	40	1700	55	3000	90	6500	200
0.20	550	20	950	35	1300	45	2300	80	4500	170
0.10	350	20	650	30	900	40	1500	65	3000	140
0.05	250	15	450	25	650	35	1000	55	2000	120

Table 2. CO₂

Pressure [MPaG]	Size									
	50 mm		65 mm		80 mm		100 mm		150 mm	
	Maximum flow value	Minimum flow value	Maximum flow value	Minimum flow value	Maximum flow value	Minimum flow value	Maximum flow value	Minimum flow value	Maximum flow value	Minimum flow value
0.98	1100	35	1850	55	2650	75	4500	130	9500	230
0.90	1050	30	1750	50	2550	75	4300	125	9100	220
0.80	1000	30	1650	50	2400	70	4050	115	8500	210
0.70	950	30	1550	45	2250	65	3800	110	8000	200
0.60	850	25	1400	40	2050	60	3500	100	7300	180
0.50	800	25	1300	40	1850	55	3150	95	6700	170
0.40	700	20	1150	35	1650	50	2800	85	5900	150
0.30	600	20	1000	30	1450	45	2400	75	5100	140
0.20	450	20	750	30	1050	40	1800	65	3800	120
0.10	300	15	500	25	700	35	1200	55	2500	100
0.05	200	15	350	20	500	30	850	45	1800	90

Performance

Reference accuracy

For the flow one tenth of maximum flow limit or more:
±3% of reading

For the flow less than maximum flow limit of one tenth:

±(Q_{at1/10}³)/Q% of reading

Q_{at1/10}: 1/10 flow of maximum flow

Q: measuring flow

Permanent pressure loss

More than 0.3 MPa of static pressure

$$P.Loss = 50 \times \left(\frac{Q}{Q_{max}} \right)^2$$

Less than 0.3 MPa of static pressure

Less than 0.3 MPa of static pressure

$$P.Loss = 0.5 \times (238 \times SP + 23) \times \left(\frac{Q}{Q_{max}} \right)^2$$

Symbol	Unit	Explain
P.Loss	[kPa]	Pressure loss of flow
Q	[Nm ³ /h]	Flow value
Qmax	[Nm ³ /h]	Maximum flow value
SP	[kPa G]	Process pressure (static pressure)

Damping:

Adjustable between 0 and 128 seconds

* When the reference temperature is set to 0 °C and the reference pressure is set to 101.325 kPa (standard conditions), the “m3/” unit for instantaneous flow rate is displayed as “Nm3/” (“N” in italics).

Low flow cutoff

Adjustable between 0 and 20% of setting range

Power failure

An EEPROM retains data record of totalized flow and various set up parameters

Function

Totalized function

Counting by one count according to the display flow unit setting.

Auto ranging function

After turning on the power or the peak value is reset, the model MVC10A/MVC10F automatically sets the measuring range at 80% of the maximum flow rate.

Leak check function

Calculate the leak rate by measuring line pressure with a built in pressure sensor.

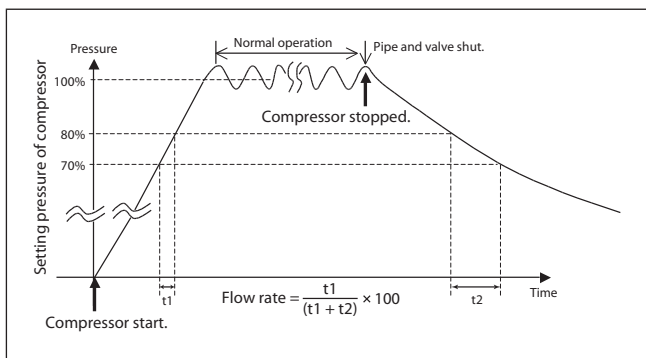

Table 3. Factory Default Setting

ITEM		Factory Default Setting
Main display		Totalized flow
Unit	Totalized flow	m ³
	Flow rate	Nm ³ /h
	Totalized cost	¥
	cost	¥/h
Damping		1 sec
Low flow cut		3% of Flow rate range
Flow rate range		Customer instruction
Leak check	Pressure setting value	0.65MPa G
Tag		XXXXXXXX
Reference temperature		0°C
Reference pressure		101.325 kPa (abs) *
Pulse weight		Customer omstruction (0.1 m ³ /pulse unless otherwise specified)
Cost rate		0 ¥/m ³
Max flow		Customer omstruction (The maximum flow rate for the pipe size unless otherwise specified)
Language		Japanese

Installation Precautions

Obey following precautions to prevent accidents, and for product to function to its best ability. Be sure to read user's manual before use of product.

Cautions After Installation

- Please use this product by attaching it to the main piping not bypass piping.
- Depending on piping combinations, the installed flow meter may produce vibrations or fluid sounds. It is recommended, where possible, that the product be used on simple piping where there are elbow-pipe, Tshaped pipe, reducing pipe, valves or filters.
- When installing onto vertical piping, zero the product with the piping at working pressure after the product is installed.

Cautions During and After Installation

⚠ CAUTION

- For vertical installation, be sure to adjust zero output at working pressure.

⚠ CAUTION

- Do not step on product. May break and cause injuries.
- Do not tap window with hard tools. Glass may break and cause injuries.
- During installation, always hold product with sufficient footing and use safety shoes. Product is heavy in weight and may cause injuries when dropped.

⚠ WARNING

- Be sure that no pressure remains within piping when removing product from piping.
- Be careful of burns when process temperature is high. Product temperature will rise with process and remain so for some time.

Cautions Concerning Measuring Fluids

- The measuring fluid contains a insignificant amount of water. Air compressed by a compressor especially contains a considerable amount of water. Water may condense in the pipeline and accumulate in the connecting piping of the product. Drain the accumulated water as required (for vertical piping installation and remote type).
- CO₂ may condense during high-pressure and low-temperature measurement. When using the product under such conditions, it is recommended that the piping be heat-insulated.

Cautions Concerning Ambient Conditions

- Use product where there is no sudden change in ambient temperature. May cause output errors. Gradual changes should also be avoided as much as possible.
- If possible, keep product out of direct sunlight. Plastic material of case lid may be damaged.
- Keep product out of direct rain and wind.
- Do not use product in corrosive gas surroundings.
- Avoid pipe vibrations as much as possible. (Vibrations to be below 5m/S²)
- Cut off power supply to product when welding nearby piping. May cause damages according to method of grounding. Welding instruments should be grounded directly.

Cautions Concerning Electrical Wiring

⚠ CAUTION

- Carefully confirm wiring terminals and connect accordingly. Incorrect wiring may cause irreparable damages to product.
- Be sure to supply correct power according to product's specification. Incorrect power supply may cause irreparable damages to product.

⚠ WARNING

- When wiring, be sure to turn off power before opening lid. May cause electric shock.
- Do not conduct wiring when lines are alive. May cause electric shock.

⚠ WARNING

- Impact to transmitter can damage sensor module.

MODEL SELECTIONS

The Multivariable Air Flow Meter

Basic model no.		Selections							Options	
Integral type	MVC10A	-							-	
Remote type	MVC10F	-							-	
Line size	50 mm		050							
	65 mm		065							
	80 mm		080							
	100 mm		100							
	150 mm		150							
Customer code	Standard				STD					
Power supply	Standard (90 to 250V AC)					A				
Process connection	Flange JIS 10K						J1			
Installation / flow direction	Horizontal piping / left to right							HL		
	Horizontal piping / right to left							HR		
	Vertical piping / upward to downward							VH		
	Vertical piping / downward to upward							VL		
Face to face dimension	Standard							S		
Calibration	Standard (AIR)								1	
	Standard (N ₂)								2	
	Standard(CO ₂)								3	
Finish paint	Std. corrosion-proof finish									X
Options	No option									X
	Test report									A
	Set the tag number									C

Electrical wiring

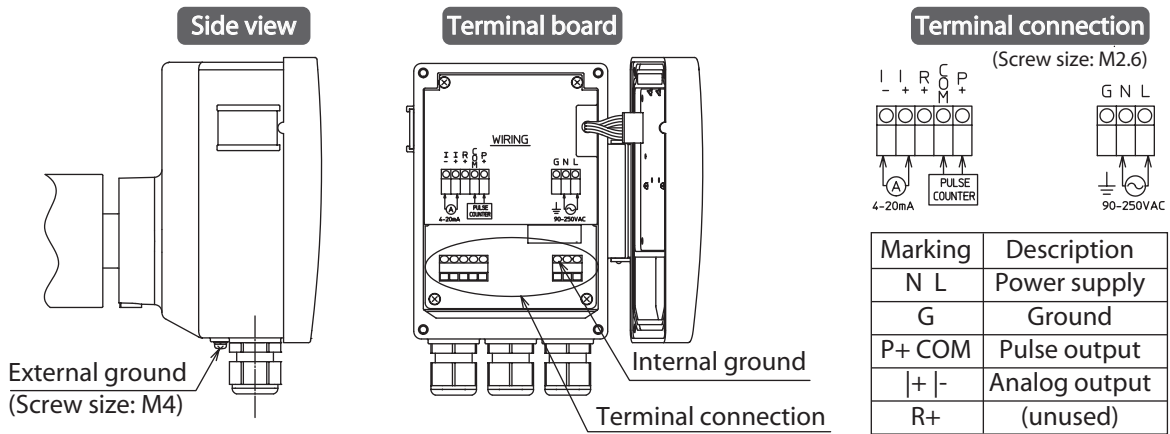

DIMENSIONS**Model MVC10A horizontal installation**

[Unit: mm]

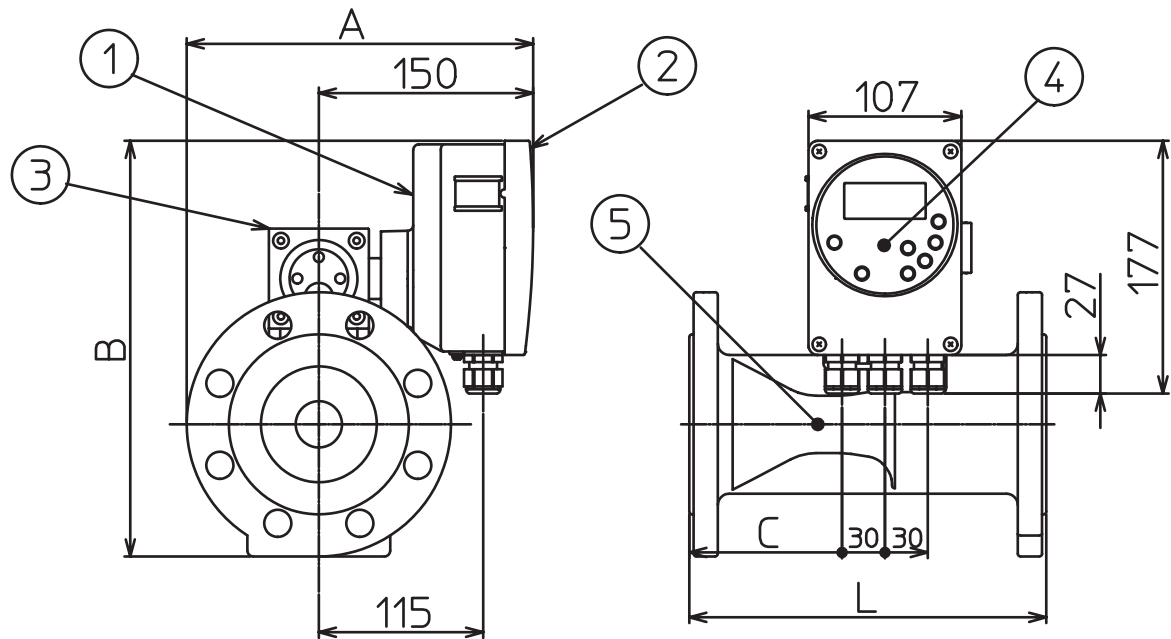
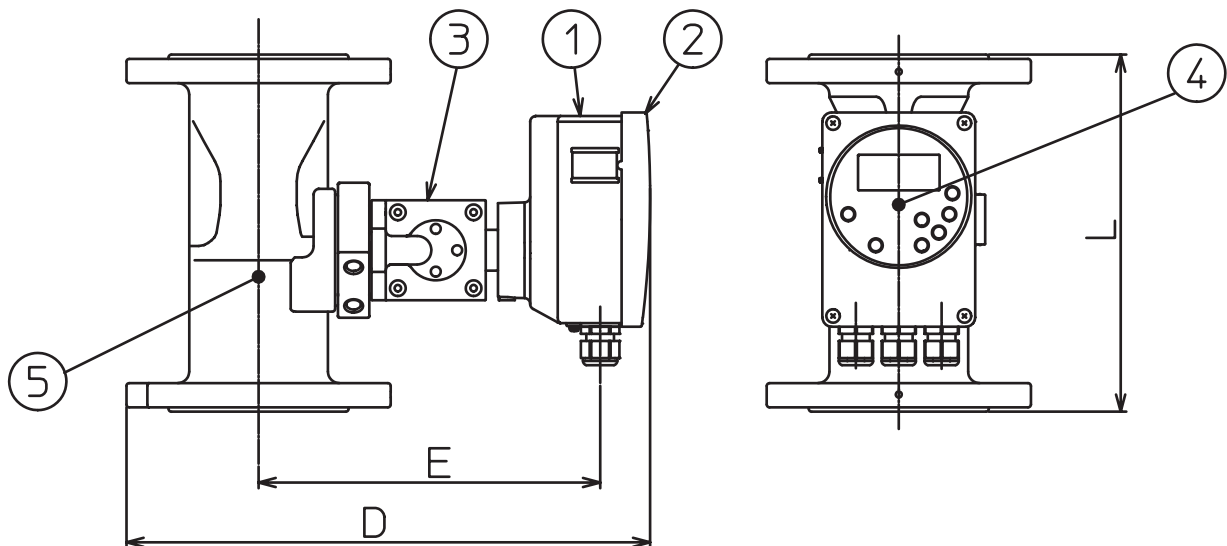
**Model MVC10A vertical installation****Dimensions and weight**

Flange size	50 mm	65 mm	80 mm	100 mm	150 mm
A	228	238	243	255	290
B	259	285	290	318	385
C	70	104	108	154	205
D	335	350	365	395	460
E	222	227	238	254	284
L	200	250	250	300	350
Flange	According to JIS standards				
Weight	9 kg	11 kg	13 kg	18.5 kg	39.5 kg

Materials

Key no.	Part name	Material
1	Case	ADC 12
2	Case lid	Polycarbonate
3	Cover flange	SCS 13
4	Screen sheet	Polyethylene
5	Flow tube	SCS 13

Model MVC10F

[Unit: mm]

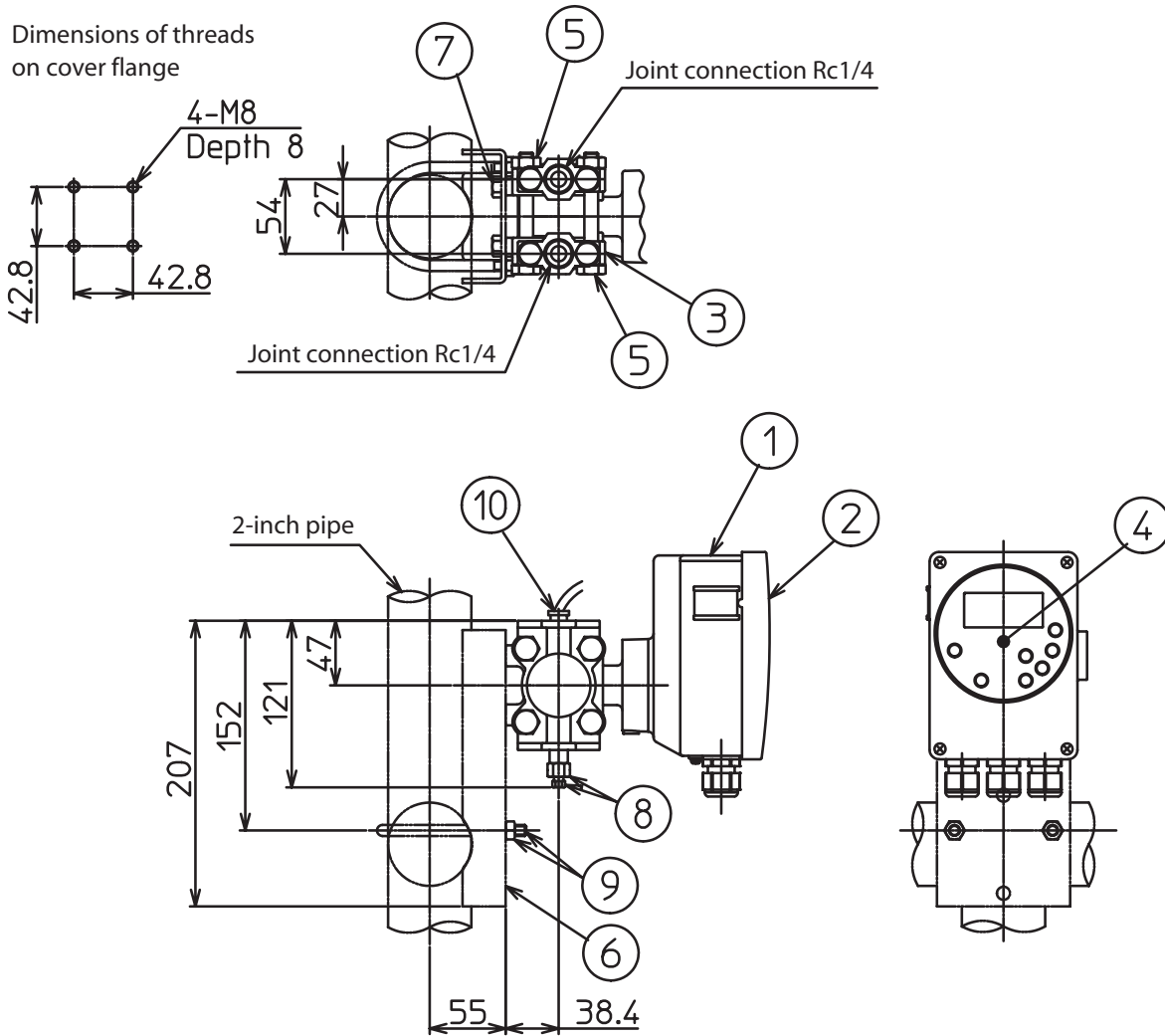

Materials

Key no.	Part name	Material
1	Case	ADC 12
2	Case lid	Polycarbonate
3	Cover flange	SCS 13
4	Screen sheet	Polyethylene
5	Bolt / Nut	SUS304
6	Bracket	SUS304
7	Bolt	SUS304
8	Vent / Drain plug	SUS316
9	U bolt / Nut	SUS304
10	Tube / Tube fitting	Nylon / Brass + POM

Please read "Terms and Conditions" from the following URL before ordering and use.
<https://www.azbil.com/products/factory/order.html>

Specifications are subject to change without notice.



Azbil Corporation
 Advanced Automation Company

1-12-2 Kawana, Fujisawa
 Kanagawa 251-8522 Japan
 URL: <https://www.azbil.com/>

1st edition: Oct. 2004
 6th edition: Apr. 2020

No part of this publication may be reproduced or duplicated without the prior written permission of Azbil Corporation.