

TSD-7·7F

Features

1. Four functions (STOP / BY-PASS / TRAP / TEST) can be switched easily with a spanner or monkey wrench.
2. The integrated bypass function helps reduce piping and construction work costs significantly.
3. Bimetal solves air-binding problem and ensures a smooth discharge of cold condensate or air at the start of operation, enabling steam equipment to efficiently start to run.
4. Can be checked without being affected by back pressure.
5. The stainless steel valve disc and valve seat are subjected to special heat treatment and very durable.
6. Equipped with a built-in strainer.
7. Can be installed vertically or horizontally as desired.
8. Rain cover is available as options for outdoor use.



TSD-7



TSD-7F

Specifications

Model		TSD-7	TSD-7F
Application		Steam condensate	
Working pressure		0.035-1.0 MPa	
Allowable back pressure		50% of inlet pressure	
Maximum temperature		183°C	
Installation posture		At any angle between vertical and horizontal (Do not put the cover under the horizontal level.)	
Material	Body	Ductile cast iron	
	Disc, seat	Stainless steel (special heat treatment)	
Connection		JIS Rc screwed	JIS 10K FF flanged

Dimensions (mm) and Weights (kg)

●TSD-7

Nominal size	d	H	Weight
15A	Rc 1/2	107	2.5
20A	Rc 3/4	109	2.6
25A	Rc 1	115	2.7

●TSD-7F

Nominal size	L	Weight
15A	156	4.1
20A	160	4.6
25A	160	5.7

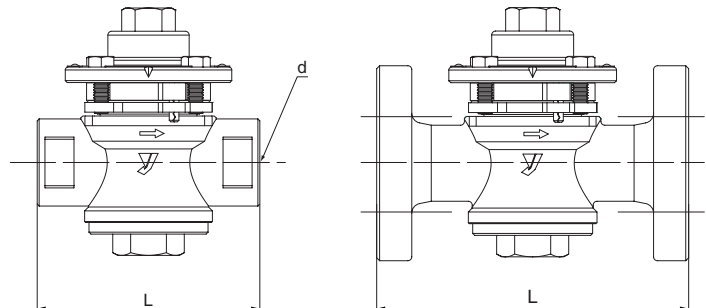

Maximum Continuous Discharge Capacity Chart

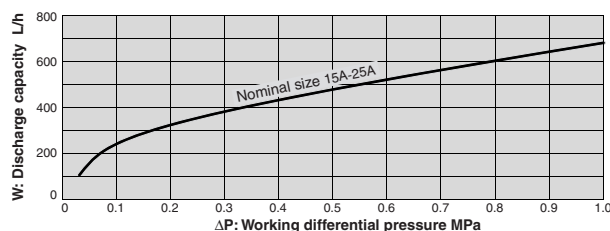

- The discharge capacity shown in the chart on the left is the maximum value.
In designing a system, select a steam trap with a sufficient safety factor (four to five times the regular level). That is, for example, if a discharge capacity of 100 kg/h is required, select a steam trap capable of discharging 400 to 500 kg/h.